



Screening and Processing



Drying System



Wood Yard



Conveying solutions in the cement industry



Maintenance and Service



Waste to Fuel



Waste to Flame



Waste to Electricity



Biomass Fuel Handling



Pneumatic Conveying

INDUSTRIAL PROJECT AND SERVICE

www.ispm-service.com





ISPM-Service est une entreprise portugaise créée en 2015 sur un concept innovant et environnemental, orientée par des valeurs de développement durable dans une ère industrialisée où la production d'énergie grâce à la combustion des déchets est une manière de traiter le problème des déchets et d'en retirer un profit. **ISPM** est une entreprise flexible, enthousiaste, socialement responsable et adaptable aux changements. Notre entreprise se caractérise principalement par un effort commun: avec nos partenaires et représentants, nous concevons et assemblons des équipements et des projets «clés en main» dans plusieurs domaines. Nous avons une assistance technique avec des professionnels motivés et hautement qualifiés. Surmonter les défis, chercher à générer et implanter des nouvelles solutions technologiques, innovantes et out of the box font partie de nos préoccupations quotidiennes et de notre vision à long terme pour **ISPM-Service**. Nous sommes une entreprise visionnaire, nous travaillons aujourd'hui pour demain, le début de l'avenir.

**LA SOLUTION DE
L'AVENIR AU
PRÉSENT**

Paulo Teixeira



ISPM a été nommé officiellement revendeur de:

*BMH Technology au Portugal et en France;
Jeffrey Rader, Stela et Aumund au Portugal;
Demuth au Portugal, en Espagne et en France;
Et revendeur agréé de BMH au Brésil*





Waste to Fuel

Le procédé TYRANNOSAURUS® Waste to Fuel valorise les déchets en grande disponibilité moyennant un faible coût de production.

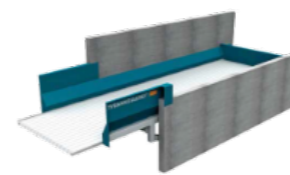

TYRANNOSAURUS® Feeders

Les alimentateurs Tyrannosaurus® permettent un chargement optimal de déchiqueteuses/broyeurs assurant ainsi continuellement une capacité maximale.



TYRANNOSAURUS® 9900 Main Shredders

Les déchiqueteuses Tyrannosaurus® 9900 sont les plus grosses et les plus robustes déchiqueteuses de déchets au monde.



TYRANNOSAURUS® 1500 Fines Screens

Les cribles fins de la série 1500 de Tyrannosaurus® séparent les fines, comme le sable, le verre, la terre du matériau.

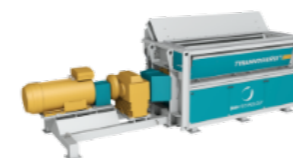

TYRANNOSAURUS® 1200 Fine Shredders

Les cribles fins de la série 1200 de Tyrannosaurus® sont utilisés pour réduire la granulométrie du produit à 0x25mm.



Screw conveyor

Vis convoyeuse: ces vis constituent un moyen économique pour le transport de vrac sur de courtes distances.

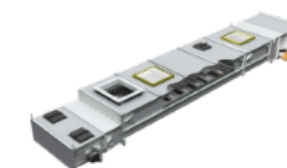

Drag Chain Conveyors

Convoyeurs à chaîne: c'est le moyen idéal d'assurer sûreté et sécurité de transport de vrac dans de nombreux processus.

Tous nos équipements travaillent en symbiose avec un forte automatisation pour optimiser la capacité de production et la qualité du combustible. Toutes les solutions de transformation de déchets en combustible de technologie BMH sont adaptées à la spécificité des déchets et à la qualité de combustible souhaitée.

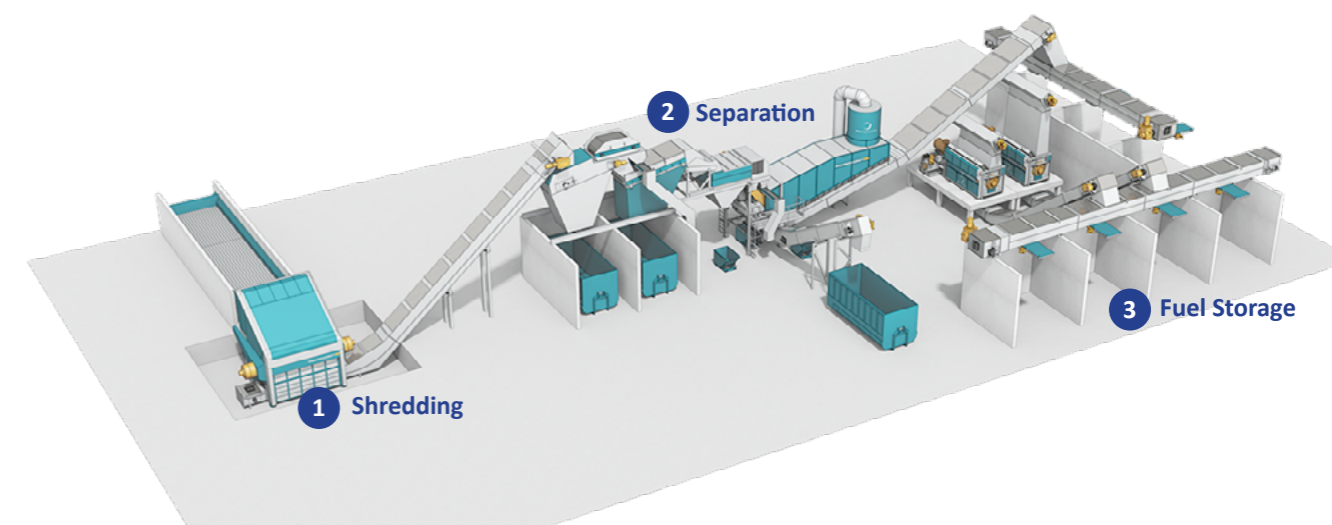

Some see
a problem,
others see an
opportunity.

DO YOU WANT TO TURN WASTE TO FUEL AND PROFIT?

The best way to do that is to get a complete TYRANNOSAURUS® plant from BMH Technology. You will get the strongest and smartest waste-to-fuel system there is, delivered turnkey in a compact layout. The Tyrannosaurus System gives you the best SRF* in the world. And lots of it. Just one production line will process as much as 1200 tonnes of MSW (Municipal Solid Waste) or 600 tonnes of industrial waste or car tyres per day.

And not only that: Tyrannosaurus will achieve this with high availability, low production cost, low maintenance cost and no constant surveillance.

* SRF

Solid Recovered Fuel by mandate of the European commission: CEN/TC343.

The calorific value of standard SRF is almost the same as that of coal (15-20 MJ/kg compared to approximately 25 MJ/kg), but the fossil carbon dioxide emissions are almost five times less. SRF has only very little chlorine or sulphur. Furthermore, SRF is a local fuel, coming from inexhaustible raw material sources. Its usage will contribute to solving important issues of waste management. Not only is SRF the cheapest fuel available, but its application can also enable you to benefit from the freed marketable CO₂ credits.

TYRANNOSAURUS® System

The process starts with the raw material in the feeder. Tyrannosaurus Feeder is automatized to work optimally together with the shredder. If the shredder has a big mouthful to chew, the feeder slows down, allowing the production line always to work at maximum capacity.

Tyrannosaurus Shredder is simply the biggest, strongest and smartest shredder in the world. He weighs up to 90 tonnes, is made of a 60 mm solid steel frame and never stops working. Not only is he robust, but he is intelligent, too: MIPS® (Massive

Impact Protection System) means that he will spit out bigger pieces of metal that cannot be crushed and keep on shredding. And shred he will. At maximum capacity, he can reduce particle size to 75 mm in one single stage. ZeroGap® shredding means that particle size and quality are maintained even with the wear of knives. The knives are hydraulically adjustable to keep on working optimally and to lengthen the service interval.

After ferrous metals have been separated by belt magnets, Tyrannosaurus Fines Screen separates

TYRANNOSAURUS® MSW Pretreatment Process

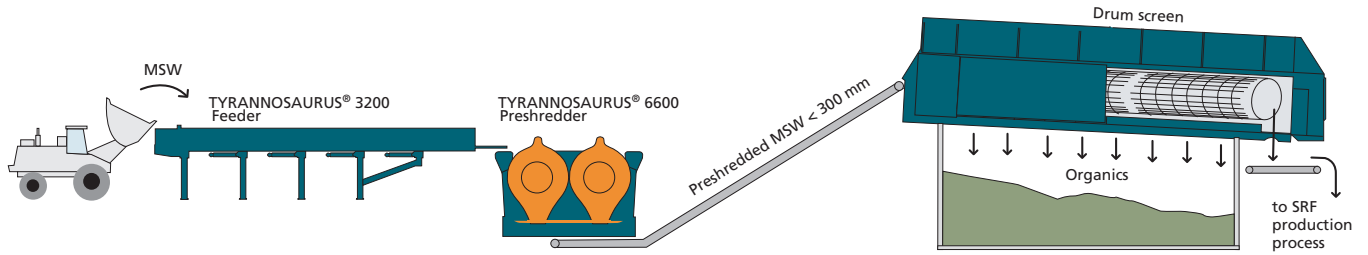

TYRANNOSAURUS® SRF Production Process

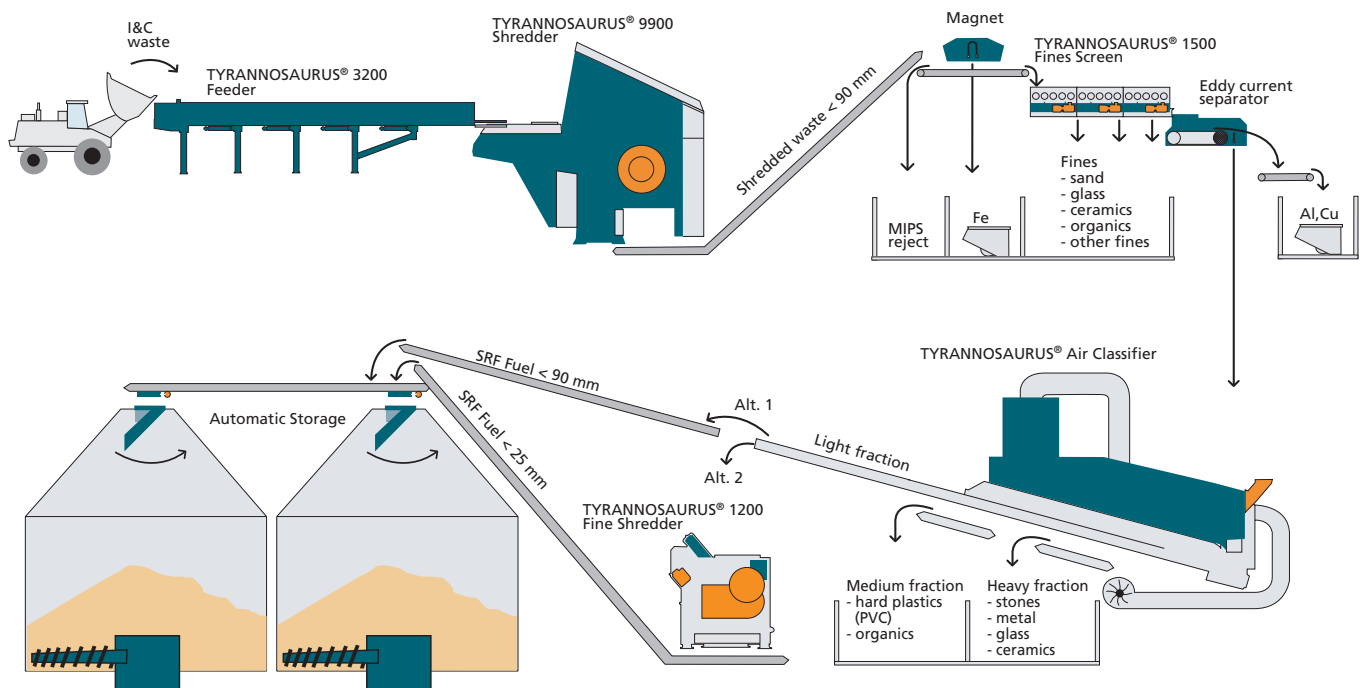

sand, glass, soil, organics and other small heavy and wet particles. This is followed by separating conductive metals by eddy current separators.

The final touch is given by Tyrannosaurus Air Classifier. This is the decisive stage concerning the quality of the fuel. In the Tyrannosaurus System, you can adjust the process online, allowing you to make the optimal fuel for the end user, for example cement kiln or power plant. Should smaller particle sizes (20 – 25 mm) be needed, Tyrannosaurus Fine Shredders – the biggest in the world – can be added to the production line.

Pretreatment Process

Not all waste is equal though, nor all combustion processes. Should the quantities of wet organics in the raw material be high, as usually is the case with MSW, they should be separated before the actual SRF production. The Tyrannosaurus MSW Pretreatment Process starts with a receiving feeder which works as a buffer to feed the Preshredder. Tyrannosaurus Preshredder will produce about 250 mm particle size, which is then refined in the SRF process. For grate-fired incinerators, this particle size would be acceptable

as such, in which case the Preshredder could be the main shredder. The wet organics and non-recyclable materials are separated by a drum screen or a disc screen and fractions with higher calorific value are conveyed further to the Tyrannosaurus SRF Production Process.



SIMPLY SUPERIOR

In the Tyrannosaurus System, every step of the shredding and separating process is the result of long experience in process industry engineering and heavy-duty machine design. We at BMH have set the new standard for SRF production.

What does the TYRANNOSAURUS® System give you?

- turnkey delivery
- high availability
- high capacity
- minimum maintenance
- no constant surveillance
- automated process
- compact layout
- low production cost
- the best fuel quality

Taking care of your investment

The Tyrannosaurus System is the best in the world. Even the best is exposed to wear, but less than others, because BMH has a comprehensive knowledge of the process as a whole. Regular control, inspection and preventive maintenance guarantee the high availability of your production.

The fuel quality stays maximised, impurities minimised and you are in complete charge. Who better to take care of your investment than the people who designed it?

Availability is king

BMH Service crowns your waste-to-energy process

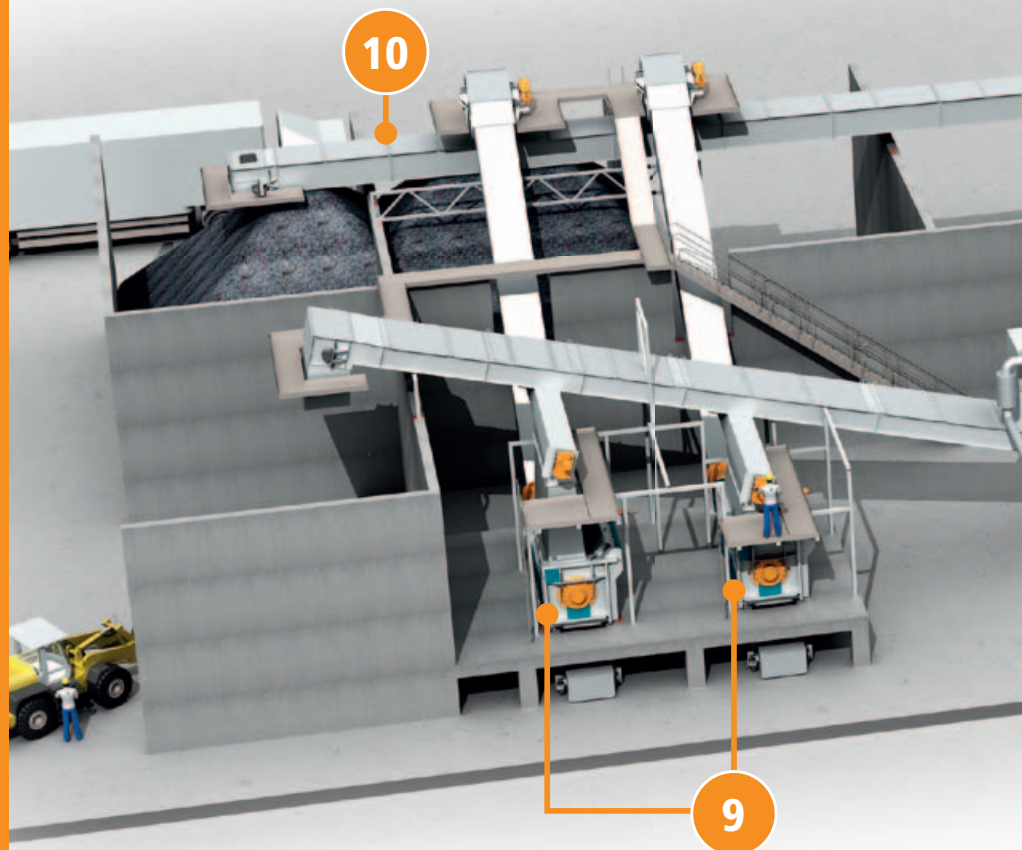

TYRANNOSAURUS® SRF Production Plant

1. TYRANNOSAURUS® 3200 Feeder
2. TYRANNOSAURUS® 9900 Shredder
3. Discharge Conveyor
4. Automatic Tramp Metal Rejection (by MIPS®)
5. Ferrous Metals Separation
6. TYRANNOSAURUS® 1500 Fines Screen
7. Non-ferrous Metals Separation
8. TYRANNOSAURUS® Air Classifier
9. TYRANNOSAURUS® 1200 Fine Shredder
10. Storage System

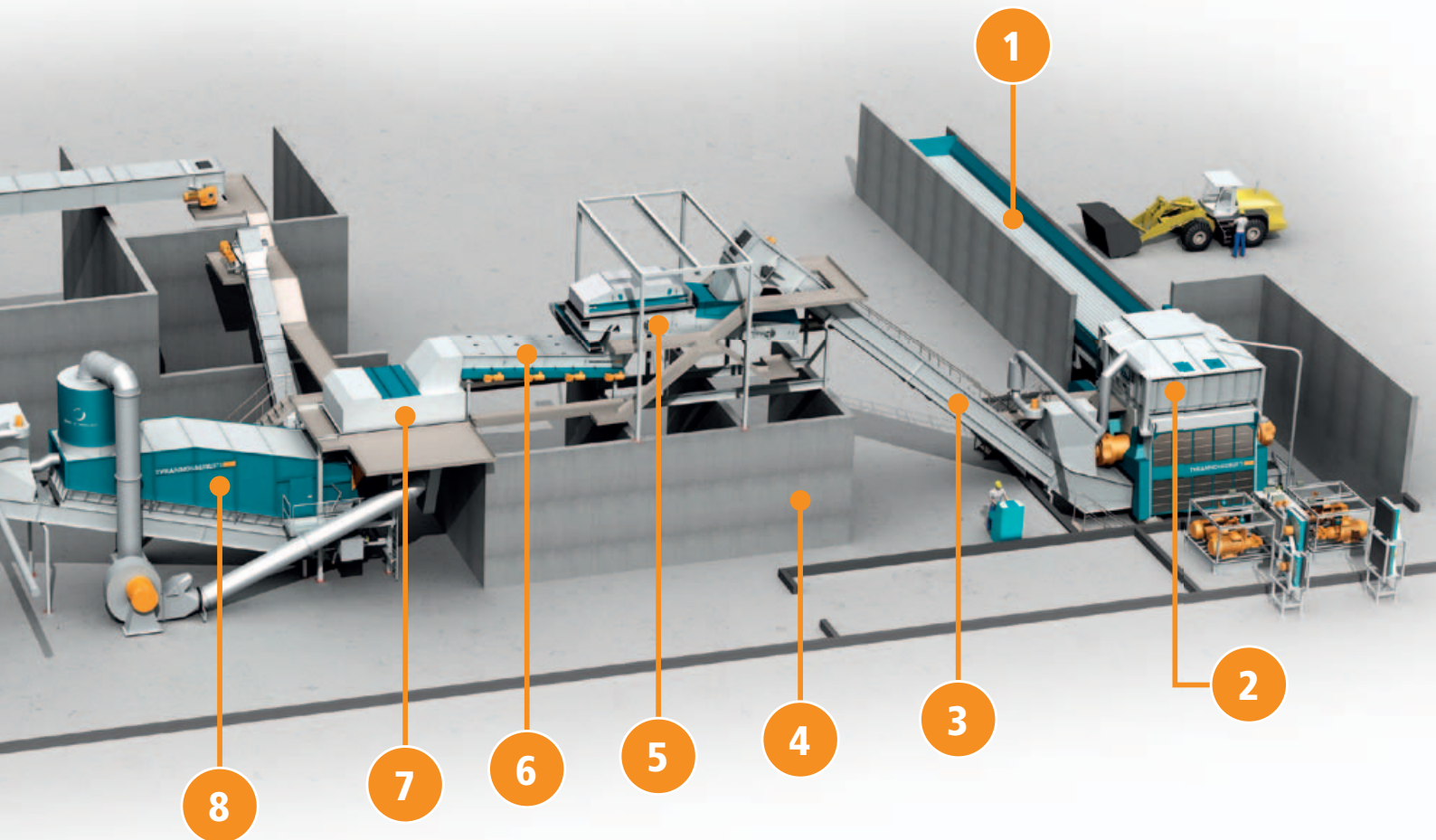

TYRANNOSAURUS® Family

TYRANNOSAURUS® 2400 & 3200 Feeders

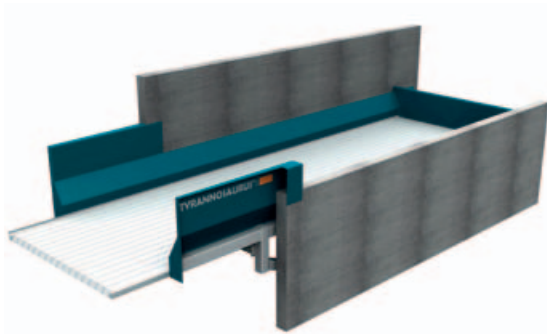

- Fully automatic optimal feeding.
- Ensures maximal process capacity.
- Heavy-duty design.
- High reliability.
- Low operating and maintenance costs.

TYRANNOSAURUS®	2412 3212	2418 3218	2424 3224
Width m	2.4 3.2	2.4 3.2	2.4 3.2
Length m	12	18	24
Power kW	37 45	37 45	37 45
Power transmission	Hydraulic	Hydraulic	Hydraulic
Capacity tonne/h	75 100	75 100	75 100

TYRANNOSAURUS® 6600 Preshredders



- For rough shredding in the pretreatment process or as the main shredder for grate-fired incinerators.
- Produces 100 – 300 mm particle size.
- Hydraulic drive.
- Easy maintenance.
- Low operating and maintenance costs.

TYRANNOSAURUS®	6603	6604	6605
Rotor length mm	1900	2500	3200
Rotor diameter mm	660	660	660
Power kW	220	264	320
Power transmission	Hydraulic	Hydraulic	Hydraulic
Capacity tonne/h	20 – 50	40 – 70	50 – 90
Weight kg	11,000	12,000	13,000

TYRANNOSAURUS® 9900 Shredders



- The world's biggest and strongest waste shredder.
- Shreds any combustible material.
- Produces uniform particle size in one single phase.
- No primary and secondary shredding needed.
- Protected from tramp metal injuries by MIPS® (Massive Impact Protection System) with fully automatic rejection of unshreddable pieces.
- Easily adjustable counter-knife system.
- Low operating and maintenance costs.
- Due to ZeroGap® shredding, wear of knives has minimal impact.

TYRANNOSAURUS®	9903	9904	9905
Rotor length mm	2400	3200	4000
Rotor diameter mm	990	990	990
Power kW	365	525	685
Power transmission	Hydraulic	Hydraulic	Hydraulic
Capacity tonne/h	10 – 25	15 – 35	25 – 50
Weight kg	50,000	65,000	80,000

TYRANNOSAURUS® 7700 Shredders



- Compact and robust design.
- Shreds any combustible material.
- Produces uniform particle size in one single phase.
- Protected from tramp metal injuries by MIPS® (Massive Impact Protection System).
- Adjustable counter-knife system.
- Low operating and maintenance costs.

TYRANNOSAURUS®	7703	7704
Rotor length mm	2400	3200
Rotor diameter mm	770	770
Power kW	357	517
Power transmission	Hydraulic	Hydraulic
Capacity tonne/h	10 – 20	12 – 25
Weight kg	25,000	30,000

TYRANNOSAURUS® 1500 Fines Screens



- Separates sand, soil and other fines.
- Reduces the content of ash, humidity, chlorine and heavy metals.
- Rotating shafts with rubber stars.
- Adjustable throughput with speed and star gap.
- Low operating and maintenance costs.

TYRANNOSAURUS®	1501	1502	1503	1504
Width mm	1500	1500	1500	1500
Modules	1	2	3	4
Shafts	12	24	36	48
Capacity tonne/h	20	40	60	80

TYRANNOSAURUS® Air Classifiers



- Separates inert materials like glass, stones, ceramics, remaining metals and organics.
- Produces clean light fraction.
- Online adjustable.
- Low operating and maintenance costs.

TYRANNOSAURUS®	1200	2500
Width mm	1200	2500
Power kW	44	90
Capacity tonne/h	25	60

TYRANNOSAURUS® 1200 Fine Shredders

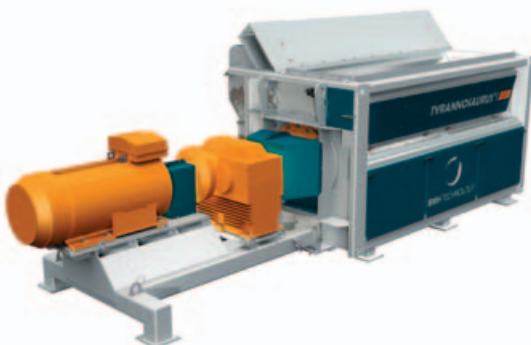

- The biggest fine shredder in the world.
- Shredding from 80 mm to 25 mm fraction.
- Easy maintenance.
- Low operating and maintenance costs.

TYRANNOSAURUS®	1203	1204
Rotor length mm	2400	3200
Rotor diameter mm	1200	1200
Power kW	250	355
Power transmission	Gear box	Gear box
Capacity tonne/h	8 – 15	12 – 20
Weight kg	20,000	26,000

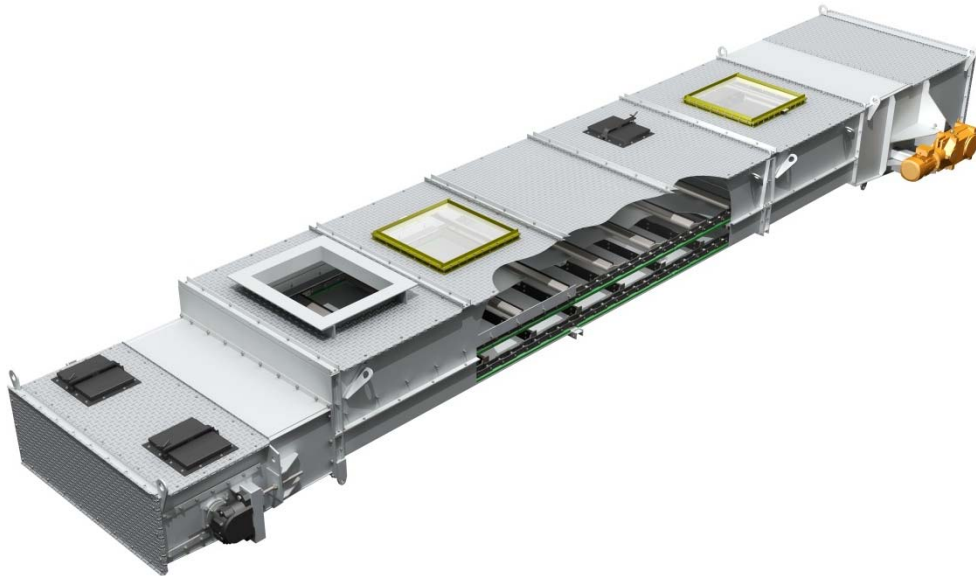

Drag chain conveyors provide a safe and reliable solution for handling powdery and dusty bulk materials in various industrial processes that require a continuous and even material flow.

Drag chain conveyors efficiently meet your needs in the following areas:

- receiving of material and transferring to intermediate storage
- filling of storage silos
- discharging from storage silos and further feeding to process equipment
- transferring of end product to storage

Width (mm)	Capacity (m ³ /h)	Recommended max. length (m)
650	150	60
800	200	60
1000	300	60
1200	400	60
1400	500	60
1600	700	60
2000	1000	60

Please note that the values in this table are only indicative. The capacities have been calculated for handling woodchip or similar materials.

IDEAL FOR HANDLING:

- biomass fuels (woodchips, bark, peat, agro biomass, pellets)
- solid recovered fuel (SRF)
- coal
- ash
- cement
- lime and minerals

Main advantages

- customised solutions based on modular engineering for fast and cost-effective installation
- horizontal or inclined installations, or a combination of both
- several inlet and outlet points
- standard components and chain types
- forged chains for heavy-duty applications
- special chains for heavy-duty and demanding conditions (heatproof structures)
- possibility to include water-cooling designs
- simple construction for straightforward maintenance
- dust-tight and spillage-free

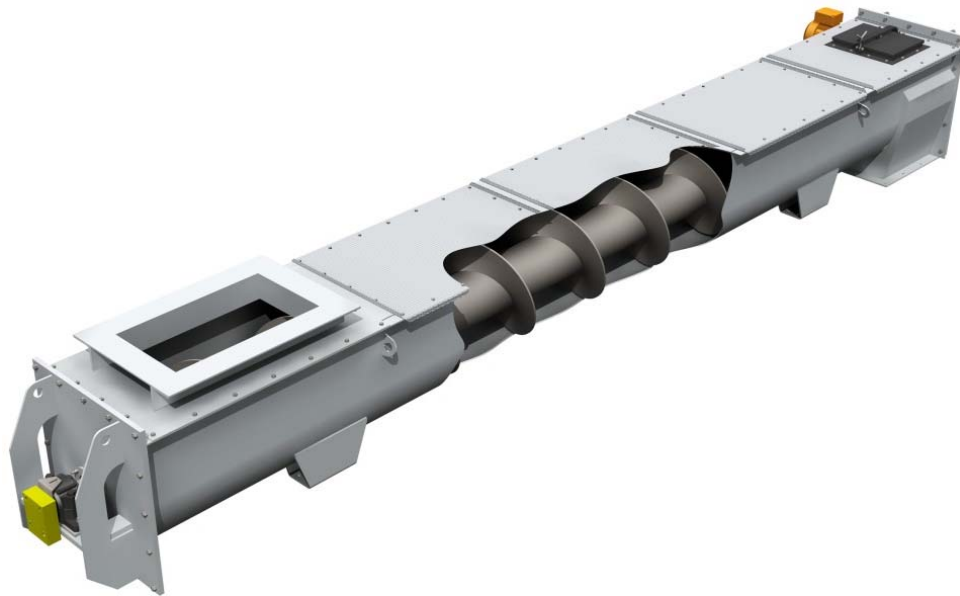

Screw conveyors are one of the most economical ways to transfer bulk materials over short distances.

Besides transferring materials from one place to another, screw conveyors can be used for:

- feeding, dosing and mixing
- distribution of material flow
- cooling (double-wall special design)
- humidifying (when equipped with internal water nozzles)
- vertical lifting of certain materials

Screw conveyors are designed to meet your specific usage requirements and to suit the materials being handled.

Screw diameter (mm)	Capacity (m ³ /h)	Recommended max. length
250	15	6.5
315	26	7.0
400	55	8.5
500	110	8.6
630	220	10.0
710	300	11.0
800	330	11.0
900	450	11.0
1000	520	12.0
1120	740	12.0
1250	850	12.0
1400	1200	14.0
1600	1400	14.0

Please note that the values in this table are only indicative. The capacities have been calculated for handling woodchip or similar materials at an inclination of 0°.

IDEAL FOR HANDLING:

- biomass fuels (woodchips, bark, peat, agro biomass, pellets)
- solid recovered fuel (SRF)
- coal
- ash
- cement
- lime and minerals

Main advantages

- standard modular design
- horizontal, inclined and vertical designs
- tubular or U-shaped conveyor trough
- special design flights for difficult sticky materials
- screws with wear-resistant facing for demanding conditions
- simple construction means easy maintenance

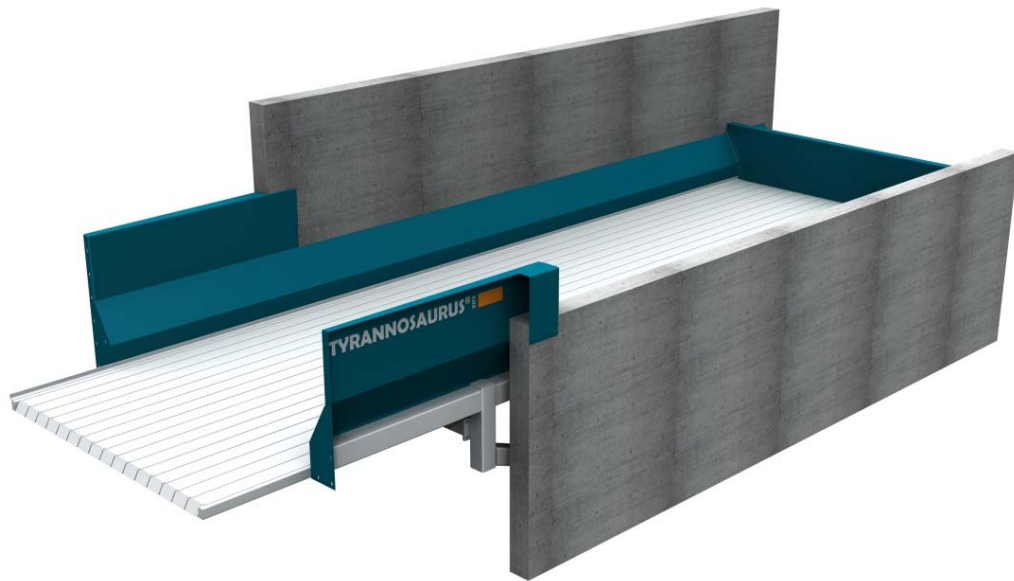

TYRANNOSAURUS® Step Feeders are an excellent solution for optimising almost any feeding process where a continuous flow of material is needed. They are typically combined with a TYRANNOSAURUS® Shredder or a TYRANNOSAURUS® Biocrusher. A step feeder serves a buffer and a feeder for the process lengthening the loading intervals and enabling the front loader driver to take on more profitable tasks between loadings.

When attached for example to a shredder, TYRANNOSAURUS® Step Feeders can adjust their feeding capacity according to the level measurements taken in the shredder's feed hopper. This means the production capacity is kept at its maximum level all the time. Step feeders are not only capable of handling large pieces but also carrying a huge volume of material. The fully automatic feeding ensures that the process functions are constantly optimised.

TYPE	Width (mm)	Length (m)	Capacity (m³/h)
2412	2400	12	45
2418	2400	18	65
2424	2400	24	85
3212	3200	12	60
3218	3200	18	85
3224	3200	24	115

Please note that the values in this table are only indicative and they have been calculated for handling MSW. The thickness of the material layer used in the calculation was 1.5 m.

TYRANNOSAURUS® Step Feeders have a long lifetime. The number of wear parts has been minimised resulting in low operation and maintenance costs.

SUITABLE FOR ALMOST ANY SOLID MATERIAL:

- municipal solid waste (MSW)
- industrial waste
- demolition waste wood
- bark
- stumps
- biomass

Main advantages

- high availability and long lifetime
- low investment and operating costs
- low maintenance costs
- high buffer capacity
- loading intervals lengthened
- produces an even material flow to the next process
- designed to prevent material from tangling
- efficient operation
- heavy duty design
- easy to install

WASTE TO FUEL BY TYRANNOSAURUS®

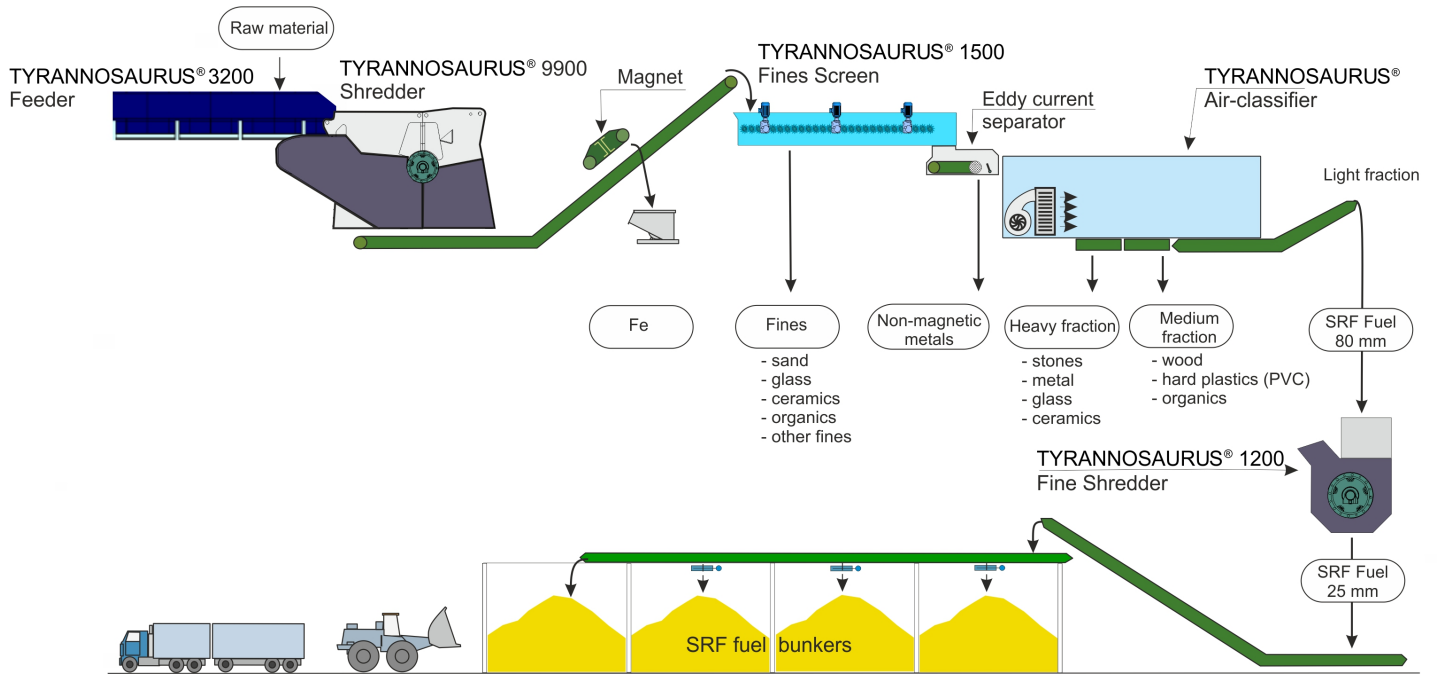

Installation Sita Starol Ltd., Chorzów, Poland

Equipment Step feeder 3.2 x 24 m
 TYRANNOSAURUS® 9905 Shredder Capacity 30 - 50 t/h
 Automatic screening & separation systems
 Conveyors
 TYRANNOSAURUS® Air Classifier
 TYRANNOSAURUS® Fine Shredder Capacity 16 t/h (30 mm)
 Electrification and automation

Project description A turn-key plant for processing commercial and industrial waste and special wastes such as mattresses and textiles, furniture, plastic and paper rolls, bigbags as well as baled materials. The plant includes a two-stage crushing process. The product produced in the first stage has the particle size 80 % smaller than 100 x 100 mm. The second-stage product size is 30 mm. The end product is used as substitute fuel in cement kilns.

Start-up January 2008

www.ispm-service.com

PORTUGAL

+351 234 304 197
Rua Dr. Alberto Soares Machado, 89
Apartado 512, EC Avenida
3801-901 Aveiro | Portugal

ispm@ispm-service.pt

FRANÇA

+33 1 43 34 81 72
+33 6 11 10 50 91
5 Place Charras Apt 67
92.400 Courbevoie | France

drousseau@ispm-service.pt

BRASIL

+55 31 2527 4426
Três Corações, 136/1004
Belo Horizonte - MG
30411-239 | Brasil

dieter.dombrowski@ispm-service.pt

