



Screening and Processing



Drying System



Wood Yard



Conveying solutions in the
cement industry



Maintenance and
Service



Waste to Fuel



Waste to Flame



Waste to Electricity



Biomass Fuel Handling



Pneumatic Conveying

INDUSTRIAL PROJECT AND SERVICE

www.ispm-service.com



A **ISPM** é uma empresa portuguesa que nasceu em 2015 com um conceito ambiental e inovador. Orientada por valores que incitam o desenvolvimento sustentável numa era industrializada, onde a geração de energia através de desperdício é, não só, uma forma de zelar pelo futuro do Planeta, mas também um meio lucrativo.

A **ISPM** é uma empresa flexível, entusiasta, socialmente responsável e adaptável às mudanças.

O nosso negócio é caracterizado principalmente por um esforço conjunto com os nossos parceiros.

Instalamos equipamentos, realizamos projetos **turn-key** e dispomos de assistência técnica com profissionais motivados e altamente qualificados. A superação de desafios, a busca pela geração e implementação de soluções tecnológicas, negócios inovadores e *out-of-the-box*, fazem parte do nosso dia-a-dia e da nossa visão a longo prazo. Somos uma empresa visionária, trabalhamos hoje para o amanhã como início do futuro.

Paulo Teixeira

A SOLUÇÃO DO
FUTURO NO
PRESENTE





A ISPM é distribuidor exclusivo da:

BMH Technology em Portugal e França;
Jeffrey Rader, Stela e Aumund em Portugal;
Demuth em Portugal, Espanha e França;
E revendedor autorizado da *BMH* no Brasil.





Biomass Fuel Handling

As soluções Biomass Fuel Handling foram pensadas para satisfazer os requisitos de produção de energia. A **BMH/ISPM** têm uma vasta experiência na área e dispõem de tecnologia de ponta com alto nível de automação o que torna esta solução altamente confiável.

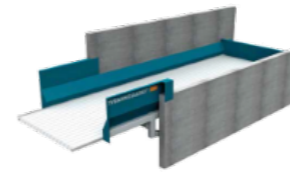

TYRANNOSAURUS® Feeders

Os alimentadores TYRANNOSAURUS® permitem uma alimentação ideal ao triturador, garantindo capacidade máxima contínua.

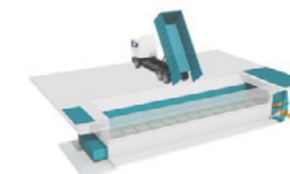

Chain reclaimer

Transportador de correntes, excelente para a recepção e transporte de diferentes tipos de materiais.

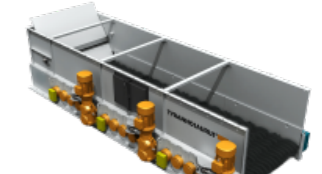

TYRANNOSAURUS® BioScreens

Os TYRANNOSAURUS® BioScreens separam as partículas corretas do combustível com grande eficácia.

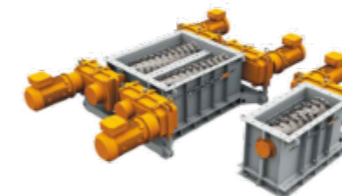

TYRANNOSAURUS® 6500 BioCrushers

Os BioCrushers TYRANNOSAURUS® são ideais para triturar material de grande dimensão, separado no processo de crivagem.



TYRANNOSAURUS® 9000 BioCrushers

É ideal para triturar detritos à base de madeira, resíduos florestais incluindo cepos e raízes.



TYRANNOSAURUS® Rotating Screw Reclaimers

Os parafusos rotativos da série TYRANNOSAURUS® são adequados para descarregar combustíveis sólidos de silos redondos fechados ou a céu aberto.



TYRANNOSAURUS® Traversing Screw Reclaimers

Os parafusos extratores automáticos com avanço contínuo TYRANNOSAURUS® são projetados para a extração de materiais a partir de grandes sistemas de armazenamento retangulares fechados ou a céu aberto.

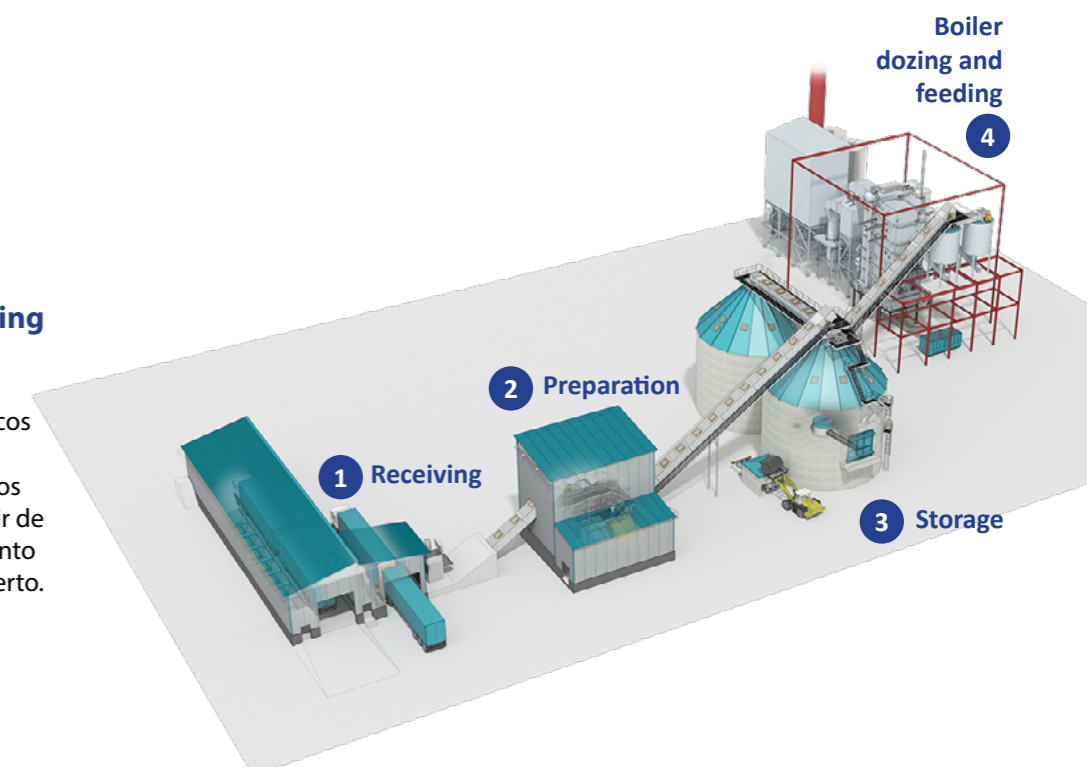

Bucket elevators are an excellent choice particularly in locations where space is limited and material needs to be transferred high on a vertical scale. They are capable of lifting a variety of materials ranging from dry, dusty fluff to heavy materials such as bottom ash.

Bucket elevators are always custom designed to meet your specific requirements and to suit the materials being handled.

Main advantages

- outstanding lifting capacity to high altitudes in confined spaces
- totally enclosed construction provides dust-tight and spillage-free operation
- specially designed buckets ensure clean and perfect discharge
- customised solutions based on modular engineering for fast and cost-effective installation
- long lifetime

BELT BUCKET ELEVATOR	
Belt width (mm)	Max capacity (m ³ /h)
500	100
650	150
800	250
1000	400
1200	600
1400	900

Please note that the capacity values in this table are only indicative and they have been calculated for handling woodchip or similar materials.

CHAIN BUCKET ELEVATOR	
Casing size (mm)	Max. capacity (m ³ /h)
400 x 1000	40
720 x 1000	80
900 x 1250	120

Please note that the capacity values in this table are only indicative and they have been calculated for handling lime or similar materials.

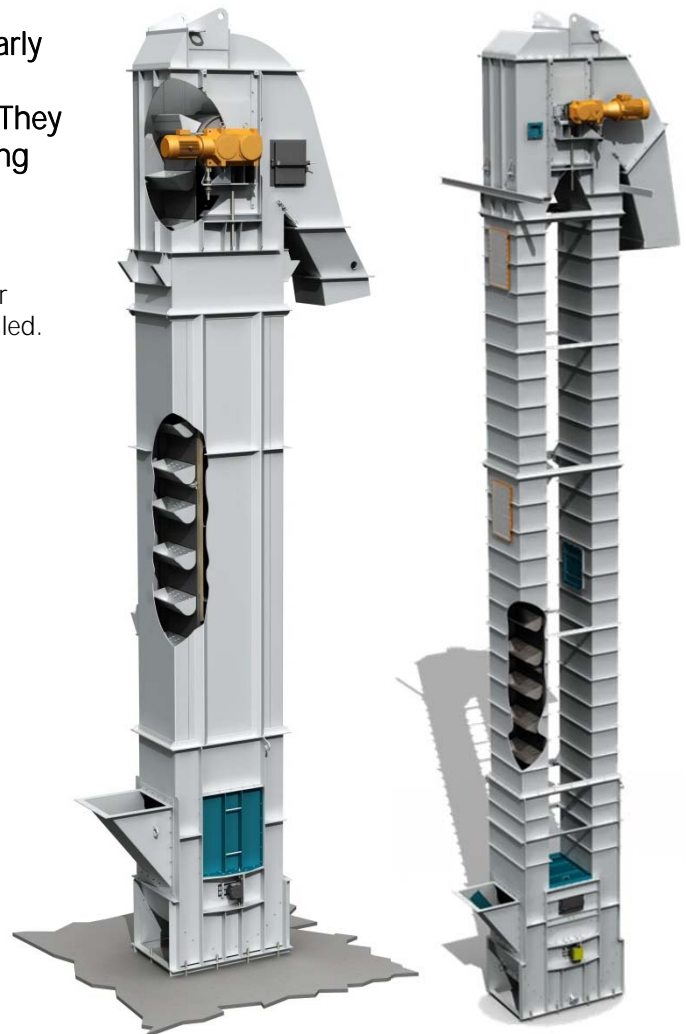

IDEAL FOR HANDLING:

Belt bucket elevators

- biomass fuels (woodchips, bark, peat, agro biomass, pellets)
- solid recovered fuel (SRF)

Chain bucket elevators

- cement
- lime
- ash

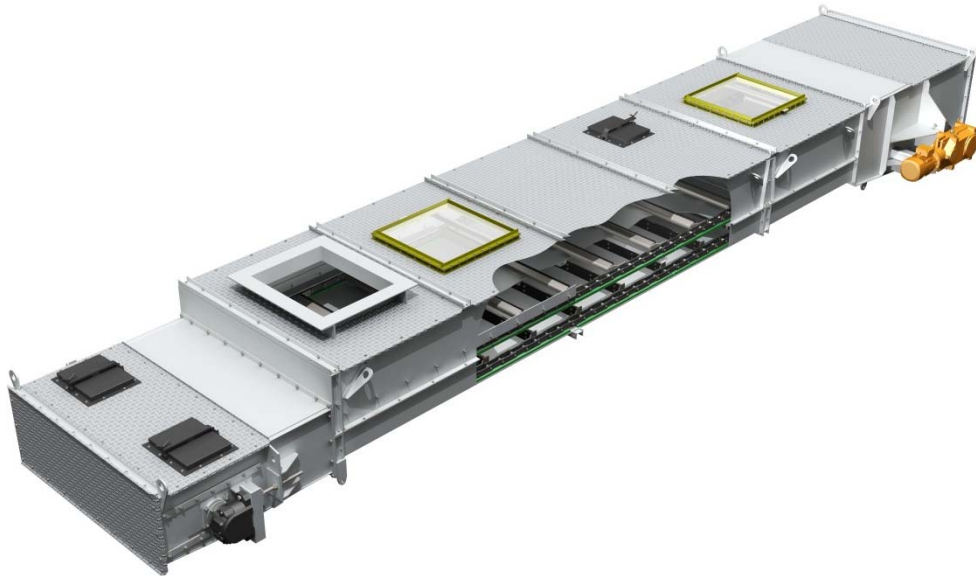

Drag chain conveyors provide a safe and reliable solution for handling powdery and dusty bulk materials in various industrial processes that require a continuous and even material flow.

Drag chain conveyors efficiently meet your needs in the following areas:

- receiving of material and transferring to intermediate storage
- filling of storage silos
- discharging from storage silos and further feeding to process equipment
- transferring of end product to storage

Width (mm)	Capacity (m ³ /h)	Recommended max. length (m)
650	150	60
800	200	60
1000	300	60
1200	400	60
1400	500	60
1600	700	60
2000	1000	60

Please note that the values in this table are only indicative. The capacities have been calculated for handling woodchip or similar materials.

IDEAL FOR HANDLING:

- biomass fuels (woodchips, bark, peat, agro biomass, pellets)
- solid recovered fuel (SRF)
- coal
- ash
- cement
- lime and minerals

Main advantages

- customised solutions based on modular engineering for fast and cost-effective installation
- horizontal or inclined installations, or a combination of both
- several inlet and outlet points
- standard components and chain types
- forged chains for heavy-duty applications
- special chains for heavy-duty and demanding conditions (heatproof structures)
- possibility to include water-cooling designs
- simple construction for straightforward maintenance
- dust-tight and spillage-free

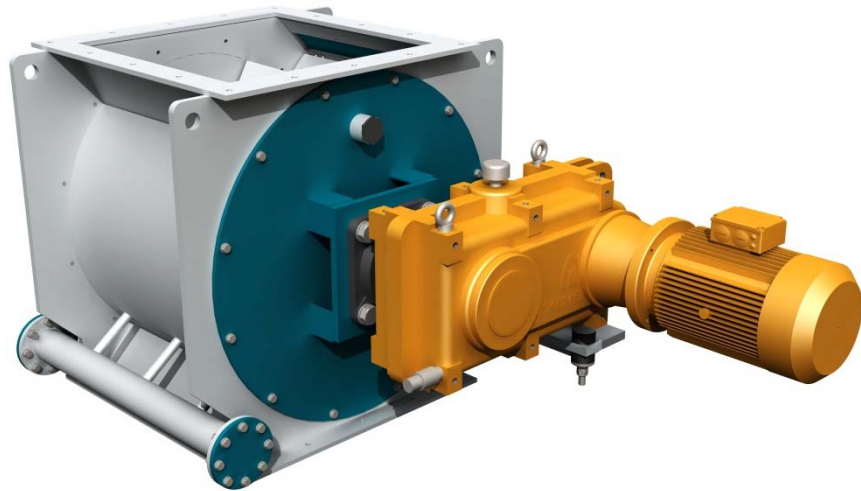

Rotary valve feeders are widely used in feeding and dosing fine-grained and dusty materials in various processes. They are always custom designed to meet your specific applications and to suit the materials being handled.

Rotary valve feeders feed e.g. coal, SRF, biomass or fly ash into a power boiler and, at the same time, act partially as a lock to prevent the backflow of gases and flames. They also serve as a dosing feeder at the silo outlet to prevent the uncontrolled discharge of material out of the silo.

Main advantages

- modular robust design with standard components
- reliable operation
- totally enclosed, dust-tight and safe construction
- easy installation
- minor need for maintenance

Special models available for your specific needs:

- LSE – Electric precipitator soda ash

TYPE	Size	Capacity (m ³ /h)
LSF Biomass, solid recovered fuel (SRF)	40/60	40
	50/60	60
	50/80	85
	63/50	100
	63/80	140
	80/80	200
	63/120	230
LSC Coal, sludge, sticky materials, (biomass)	80/120	300
	40/40	20
	40/50	30
	40/60	40
	50/60	60
	63/50	60
LSAR Ash, sand	63/80	100
	20/20	5
	30/30	15
	40/40	40
	50/50	80

Please note that the values in this table are only indicative and they have been calculated for a filling degree of 40%.

IDEAL FOR HANDLING:

- biomass fuels (woodchips, bark, peat, agro biomass, pellets)
- solid recovered fuel (SRF)
- coal
- sludge
- sticky materials
- ash
- sand

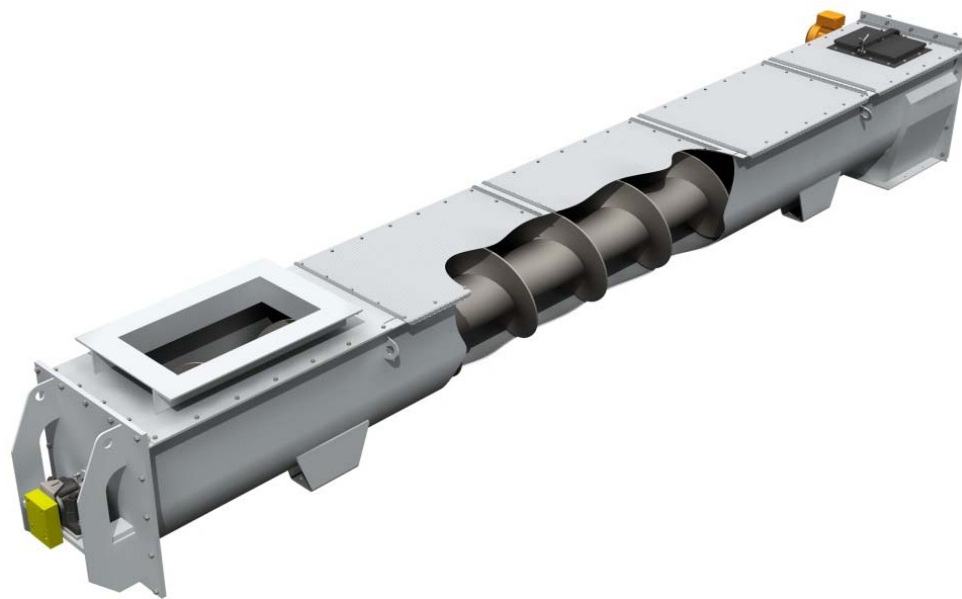

Screw conveyors are one of the most economical ways to transfer bulk materials over short distances.

Besides transferring materials from one place to another, screw conveyors can be used for:

- feeding, dosing and mixing
- distribution of material flow
- cooling (double-wall special design)
- humidifying (when equipped with internal water nozzles)
- vertical lifting of certain materials

Screw conveyors are designed to meet your specific usage requirements and to suit the materials being handled.

Screw diameter (mm)	Capacity (m ³ /h)	Recommended max. length
250	15	6.5
315	26	7.0
400	55	8.5
500	110	8.6
630	220	10.0
710	300	11.0
800	330	11.0
900	450	11.0
1000	520	12.0
1120	740	12.0
1250	850	12.0
1400	1200	14.0
1600	1400	14.0

Please note that the values in this table are only indicative. The capacities have been calculated for handling woodchip or similar materials at an inclination of 0°.

IDEAL FOR HANDLING:

- biomass fuels (woodchips, bark, peat, agro biomass, pellets)
- solid recovered fuel (SRF)
- coal
- ash
- cement
- lime and minerals

Main advantages

- standard modular design
- horizontal, inclined and vertical designs
- tubular or U-shaped conveyor trough
- special design flights for difficult sticky materials
- screws with wear-resistant facing for demanding conditions
- simple construction means easy maintenance

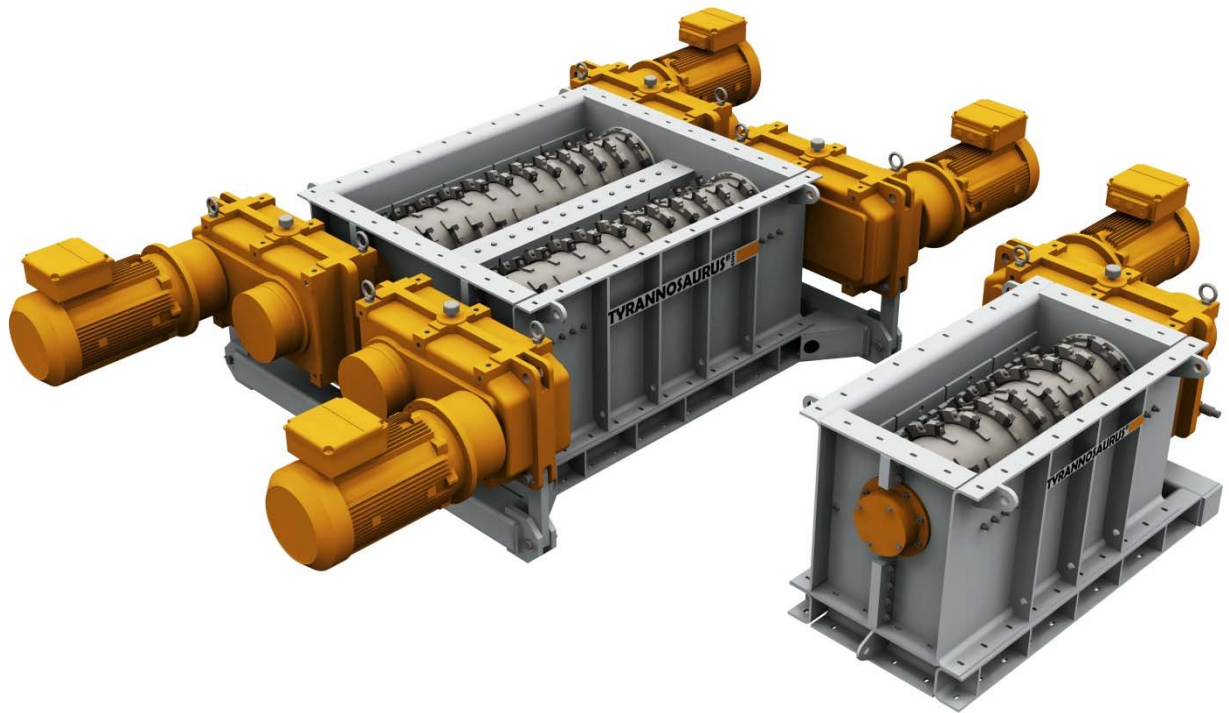

TYRANNOSAURUS® Biocrushers 6500 are a key piece of equipment in the biomass fuel preparation process. It is ideal for applications where secondary crushing of oversized biomass fuel is needed after screening to ensure a quality end product. Combined with a TYRANNOSAURUS® Bioscreen, the Biocrusher 6500 forms a dust-tight, entirely enclosed construction.

TYRANNOSAURUS® Biocrusher 6500 is available in either a one-rotor or a two-rotor design with various drive alternatives depending on the capacity requirements

TYPE	Capacity (m ³ /h)
6500-1-1200	15
6500-1-1600	20
6500-2-1600	70
6500-2-2000	90

Please note that the capacity values in this table are only indicative and they have been calculated for crushing wood-based waste.

IDEAL FOR CRUSHING:

- wood-based waste
- logging and stump residues
- stalky plant and vegetable-based residues
- packaging materials, cardboard and paper, pallets, etc.

Main advantages

- heavy-duty design incorporating unrivalled operational and technical features
- slow-speed mode minimises the risk of overheating and spark formation
- reversible running mode minimises jams
- two-way crushing against stationary counter knife ensures a longer lifetime
- turnable teeth with screw-fastening and counter-knife constructed in a modular design to enable easy maintenance
- low operating and maintenance costs



TYRANNOSAURUS® Biocrushers 9000 are a key piece of equipment in the biomass fuel production process. The biomass fuel produced at the TYRANNOSAURUS® Biocrusher 9000 station is suitable for burning in all types of boilers such as fluidized bed and gacifier.

TYRANNOSAURUS® Biocrushers are available in either a one-rotor or a two-rotor design with various drive alternatives depending on the capacity requirements and materials to be crushed. TYRANNOSAURUS® Biocrushers can be equipped with an integrated screen grate which will ensure the required end product size.

The slow-speed TYRANNOSAURUS® Biocrusher 9000 has a patented tooth system. It is designed for heavy-duty applications to reduce combustible raw materials.

TYPE	Capacity (m ³ /h)
9000-1-3200	40
9000-2-2000	50–70
9000-2-3200	70–150
9000-2-4000	120–200
9000-2-5200	150–250
9000-2-6000	200–400

Please note that the capacity values in this table are only indicative and they have been calculated for crushing wood-based waste.

IDEAL FOR CRUSHING:

- wood-based waste
- logging residues and stumps
- railway sleepers
- stalky plant and vegetable-based residues
- packaging materials, cardboard and paper, pallets, etc.

Main advantages

- sturdy, heavy-duty yet space-saving design
- simple construction means low operating and maintenance costs
- wear-resistant changeable and turnable teeth
- proven technical solutions – reliable operation
- perfect crushing performance, high efficiency
- dust-free operation
- slow-speed mode of operation minimises the risk of fire and damage from stones and metals
- turnable teeth with screw-fastening
- bolted counter-knives constructed in a modular design to enable easy maintenance
- low operating and maintenance costs



TYRANNOSAURUS® Bioscreens provide a reliable and cost-effective way to separate oversized material from the fuel flow for secondary crushing e.g. in a TYRANNOSAURUS® Biocrusher 6500.

TYRANNOSAURUS® Bioscreens were developed based on conventional disc screens. The proven technical solutions, combined with flexible modular design and innovative purpose-built performance, ensure that TYRANNOSAURUS® Bioscreens are superior to any other fuel screen in terms of both reliability and end-product quality. Higher capacities are easily achieved by increasing the number of shaft assemblies.

Width (mm)	Number of shafts	Capacity range (m ³ /h)
800	8	50–100
1000	8	100–150
1200	8	100–150
1200	12	150–300
1200	16	250–400
1600	12	250–400
1600	16	300–500
1600	24	500–800
2000	24	800–1200
2400	24	1200–1500

Please note that the capacity values in this table are only indicative and they have been calculated for screening woodchips.

IDEAL FOR CRUSHING:

- biomass fuels (woodchips, bark, peat, agro biomass, pellets)
- solid recovered fuel (SRF)
- coal

Main advantages

- high capacity per screening area
- end-product particle size is determined by the chosen disc gap
- compact, simple and dust-tight design
- self-cleaning action provided by rotation of the discs
- specially designed discs accelerate material movement and maximise screening performance
- shaft assembly construction and disc material can be chosen according to usage requirements



TYRANNOSAURUS® Circular Screw reclaimers LPE have been developed to discharge material both from silos and round, open-air storage facilities.

TYRANNOSAURUS® Circular Screw reclaimers LPE are designed to efficiently meet your needs in the following areas:

- automatic fuel reclaiming and even flow of material from storage
- capacity can be easily adjusted to process requirements

TYPE	Max capacity (m ³ /h)	Silo diameter (m)
LPE10	70	4-5
LPE20	250	4.5-7
LPE25	350	5-7
LPE30	700	8-12
LPE35	700	12-14
LPE40	800	12-16
LPE50	900	18-25
LPE55	900	26-27

Please note that the values in this table are only indicative. The capacities have been calculated for handling woodchip and similar materials.

IDEAL FOR HANDLING:

- biomass fuels (woodchips, bark, peat, agro biomass, pellets)
- solid recovered fuel (SRF)

Main advantages

- heavy-duty construction to ensure a long lifetime
- constructed from materials and equipped with special linings which best suit the use
- screws are equipped with fixed or replaceable teeth
- specially designed teeth for demanding applications
- easy access to service points and simple maintenance
- central lubrication unit
- simple and inexpensive foundations

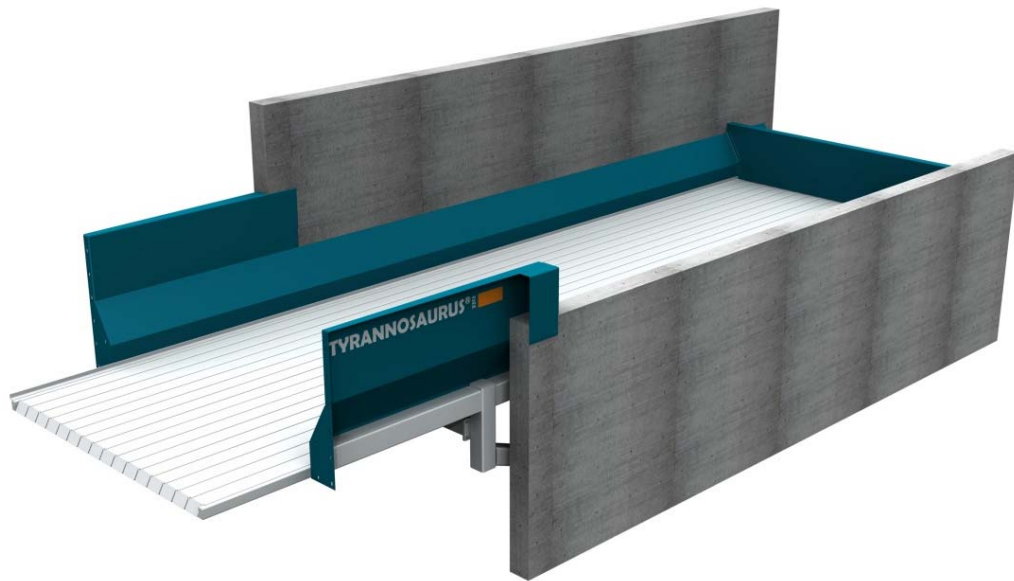

TYRANNOSAURUS® Step Feeders are an excellent solution for optimising almost any feeding process where a continuous flow of material is needed. They are typically combined with a TYRANNOSAURUS® Shredder or a TYRANNOSAURUS® Biocrusher. A step feeder serves a buffer and a feeder for the process lengthening the loading intervals and enabling the front loader driver to take on more profitable tasks between loadings.

When attached for example to a shredder, TYRANNOSAURUS® Step Feeders can adjust their feeding capacity according to the level measurements taken in the shredder's feed hopper. This means the production capacity is kept at its maximum level all the time. Step feeders are not only capable of handling large pieces but also carrying a huge volume of material. The fully automatic feeding ensures that the process functions are constantly optimised.

TYPE	Width (mm)	Length (m)	Capacity (m³/h)
2412	2400	12	45
2418	2400	18	65
2424	2400	24	85
3212	3200	12	60
3218	3200	18	85
3224	3200	24	115

Please note that the values in this table are only indicative and they have been calculated for handling MSW. The thickness of the material layer used in the calculation was 1.5 m.

TYRANNOSAURUS® Step Feeders have a long lifetime. The number of wear parts has been minimised resulting in low operation and maintenance costs.

SUITABLE FOR ALMOST ANY SOLID MATERIAL:

- municipal solid waste (MSW)
- industrial waste
- demolition waste wood
- bark
- stumps
- biomass

Main advantages

- high availability and long lifetime
- low investment and operating costs
- low maintenance costs
- high buffer capacity
- loading intervals lengthened
- produces an even material flow to the next process
- designed to prevent material from tangling
- efficient operation
- heavy duty design
- easy to install

TYRANNOSAURUS® TRAVERSING SCREW RECLAIMERS

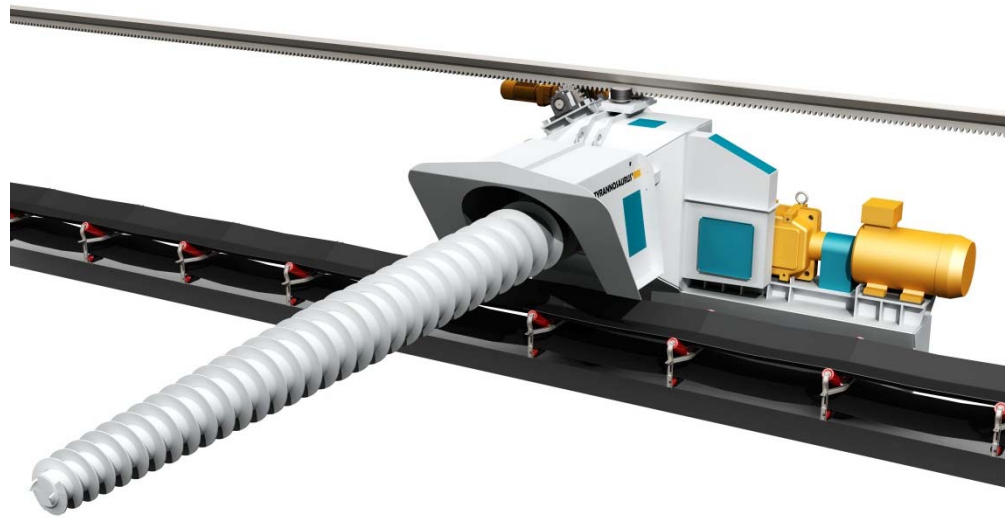

TYRANNOSAURUS® Traversing screw reclaimers LPD are designed for reclaiming material from rectangular storage silos, A-frame storage buildings, open-air piles and receiving bins. TYRANNOSAURUS® Traversing screw reclaimers LPA are designed for larger storage systems where a more extensive reclamation area is required. They are provided with supporting rail and drive arrangements in a machinery tunnel.

TYRANNOSAURUS® screw reclaimers LPD & LPA are designed to efficiently meet your needs in the following areas:

- automatic fuel reclaiming and even flow of
- material from high-volume storages
- capacity can be easily adjusted to process requirements

TYPE	Max capacity (m ³ /h)	Reclaiming area width (m)
LPD40	750	4–7
LPD50	900	6–10
LPD55	1000	8–15
LPA30	600	6–9
LPA60	1000	12–15
LPA70	1000	14–20

Please note that the values in this table are only indicative. The capacities have been calculated for handling woodchip and similar materials.

IDEAL FOR HANDLING:

- biomass fuels (woodchips, bark, peat, agro biomass, sludge, pellets)
- solid recovered fuel (SRF)

Main advantages

- heavy-duty construction to ensure a long lifetime
- constructed from materials and equipped with special linings which best suit the use
- screws with replaceable teeth for demanding needs
- easy access to service points
- central lubrication unit
- maximum traversing length even up to 300 m.

www.ispm-service.com

PORTUGAL

+351 234 304 197
Rua Dr. Alberto Soares Machado, 89
Apartado 512, EC Avenida
3801-901 Aveiro | Portugal

ispm@ispm-service.pt

FRANÇA

+33 1 43 34 81 72
+33 6 11 10 50 91
5 Place Charras Apt 67
92.400 Courbevoie | France

drousseau@ispm-service.pt

BRASIL

+55 31 2527 4426
Três Corações, 136/1004
Belo Horizonte - MG
30411-239 | Brasil

dieter.dombrowski@ispm-service.pt

